

JEE Advanced - 2020
Paper-II
(Held on 27 September 2020)

TEST PAPER
with SOLUTIONS

PART-A : PHYSICS

SECTION – 1 : (Maximum Marks : 18)

- This section contains **SIX (06)** questions.
- The answer to each question is a **SINGLE DIGIT INTEGER** ranging from 0 to 9, **BOTH INCLUSIVE**
- For each question, enter the correct integer corresponding to the answer using the mouse and the on-screen virtual numeric keypad in the place designated to enter the answer.
- Answer to each question will be evaluated according to the following marking scheme :
 - Full Marks** : +3 If ONLY the correct option is chosen;
 - Zero Marks** : 0 If none of the options is chosen (i.e. the question is unanswered);
 - Negative Marks** : -1 In all other cases.

1. A large square container with thin transparent vertical walls and filled with water (refractive index $\frac{4}{3}$) is kept on a horizontal table. A student holds a thin straight wire vertically inside the water 12 cm from one of its corners, as shown schematically in the figure. Looking at the wire from this corner, another student sees two images of the wire, located symmetrically on each side of the line of sight as shown. The separation (in cm) between these images is _____.

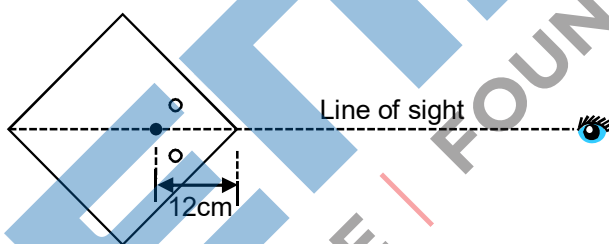

Ans. 2

Sol. We will assume that observer sees the image of object through edge $\Rightarrow \alpha = 45^\circ$

$$AB = \frac{12d\alpha}{\cos\alpha} = \frac{xd\theta}{\cos\theta}$$

By applying Snell's Law

$$\frac{4}{3}\sin\alpha = 1\sin\theta$$

$$\frac{4}{3}\cos\alpha \, d\alpha = \cos\theta \, d\theta$$

$$\Rightarrow \frac{9}{\cos^2\alpha} = \frac{x}{\cos^2\theta}$$

$$1\sin\theta = \frac{4}{3}\sin\alpha$$

$$\Rightarrow \sin\theta = \frac{2\sqrt{2}}{3} \Rightarrow x = 18 \times \frac{1}{9} = 2$$

$$d = 2x \sin(\theta - \alpha)$$

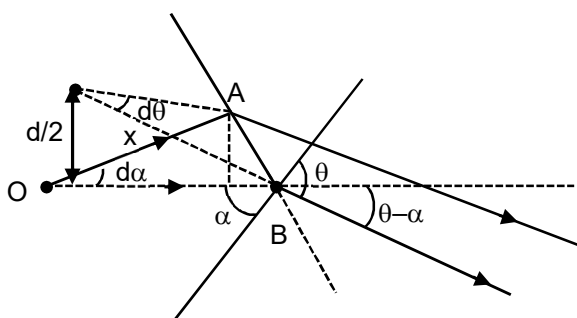

$$= 4 \times \frac{1}{\sqrt{2}} \left(\frac{2\sqrt{2}}{3} - \frac{1}{3} \right) = \frac{8 - 2\sqrt{2}}{3} \approx 1.73 \approx 2$$

2. A train with cross-sectional area S_t is moving with speed v_t inside a long tunnel of cross-sectional area S_0 ($S_0 = 4S_t$). Assume that almost all the air (density ρ) in front of the train flows back between its sides and the walls of the tunnel. Also, the air flow with respect to the train is steady and laminar. Take the ambient pressure and that inside the train to be p_0 . If the pressure in the region between the sides of the train and the tunnel walls is p , then $p_0 - p = \frac{7}{2N} \rho v_t^2$. The value of N is _____.

Ans. 9

Sol. Applying Bernoulli's equation

$$P_0 + \frac{1}{2} \rho v_t^2 = P + \frac{1}{2} \rho v^2$$

$$P_0 - P = \frac{1}{2} \rho (v^2 - v_t^2) \quad \dots (i)$$

From equation of continuity

$$\text{Also, } 4S_t v_t = v \times 3S_t \Rightarrow v = \frac{4}{3} v_t \quad \dots (ii)$$

From (i) and (ii)

$$P_0 - P = \frac{1}{2} \rho \left(\frac{16}{9} v_t^2 - v_t^2 \right) = \frac{1}{2} \rho \frac{7v_t^2}{9}$$

$$\therefore N = 9$$

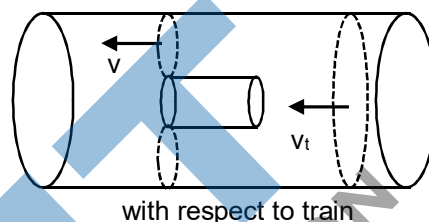

3. Two large circular discs separated by a distance of 0.01 m are connected to a battery via a switch as shown in the figure. Charged oil drops of density 900 kg m^{-3} are released through a tiny hole at the center of the top disc. Once some oil drops achieve terminal velocity, the switch is closed to apply a voltage of 200 V across the discs. As a result, an oil drop of radius $8 \times 10^{-7} \text{ m}$ stops moving vertically and floats between the discs. The number of electrons present in this oil drop is _____. (neglect the buoyancy force, take acceleration due to gravity $= 10 \text{ ms}^{-2}$ and charge on an electron (e) $= 1.6 \times 10^{-19} \text{ C}$)

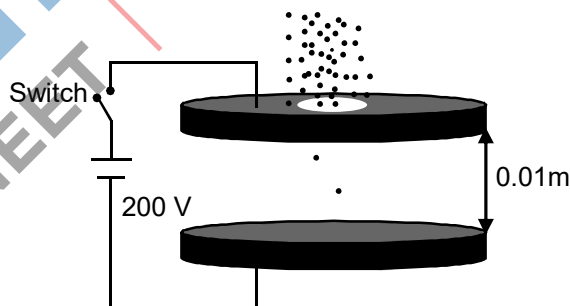

Ans. 6

Sol. $E = \frac{V}{d} = \frac{200}{0.01} = 2 \times 10^4 \text{ V/m}$

When terminal velocity is achieved

$$qE = mg$$

$$\Rightarrow n \times 1.6 \times 10^{-19} \times 2 \times 10^4 = \frac{4\pi}{3} (8 \times 10^{-7})^3 \times 900 \times 10$$

$$\Rightarrow n \approx 6$$

4. A hot air balloon is carrying some passengers, and a few sandbags of mass 1 kg each so that its total mass is 480 kg. Its effective volume giving the balloon its buoyancy is V . The balloon is floating at an equilibrium height of 100 m. When N number of sandbags are thrown out, the balloon rises to a new equilibrium height close to 150 m with its volume V remaining unchanged. If the variation of the density of air with height h from the ground is $\rho(h) = \rho_0 e^{-\frac{h}{h_0}}$, where $\rho_0 = 1.25 \text{ kg m}^{-3}$ and $h_0 = 6000 \text{ m}$, the value of N is _____.

Ans. 4

Sol. $480 \times g = V\rho_1 g$

$$(480 - N)g = V\rho_2 g$$

$$\frac{480 - N}{480} = \frac{\rho_2}{\rho_1}$$

$$\left(1 - \frac{N}{480}\right) = \frac{e^{-h_1/h_0}}{e^{-h_2/h_0}} = e^{\frac{h_1 - h_2}{h_0}} = e^{-\frac{50}{6000}}$$

$$1 - \frac{N}{480} = 1 - \frac{50}{6000} \Rightarrow N = \frac{50 \times 480}{6000} = 4$$



5. A point charge q of mass m is suspended vertically by a string of length ℓ . A point dipole of dipole moment p is now brought towards q from infinity so that the charge moves away. The final equilibrium position of the system including the direction of the dipole, the angles and distances is shown in the figure below. If the work done in bringing the dipole to this position is $N \times (mgh)$, where g is the acceleration due to gravity, then the value of N is _____. (Note that for three coplanar forces keeping a point mass in equilibrium, $\frac{F}{\sin\theta}$ is the same for all forces, where F is any one of the forces and θ is the angle between the other two forces)

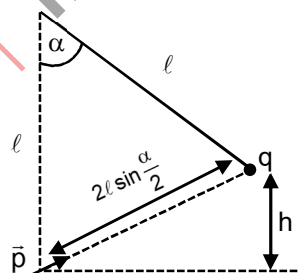

Ans. 2

Sol. $U_i = 0$

$$U_f = \frac{kqP}{\left(2\ell \sin \frac{\alpha}{2}\right)^2} + mgh \dots (i)$$

Now, from ΔOAB

$$\alpha + 90 - \theta + 90 - \theta = 180$$

$$\Rightarrow \alpha = 2\theta$$

From ΔABC : $h = 2\ell \sin\left(\frac{\alpha}{2}\right) \sin\theta$

$$h = 2\ell \sin\left(\frac{\alpha}{2}\right) \sin\left(\frac{\alpha}{2}\right)$$

$$\Rightarrow h = 2\ell \sin^2\left(\frac{\alpha}{2}\right)$$

Now charge is in equilibrium at point B.

So, using sine rule

$$\Rightarrow \frac{mg}{\sin\left[90 + \frac{\alpha}{2}\right]} = \frac{qE}{\sin[180 - 2\theta]}$$

$$\Rightarrow \frac{mg}{\cos \frac{\alpha}{2}} = \frac{qE}{\sin 2\theta}$$

$$\Rightarrow \frac{mg}{\cos \frac{\alpha}{2}} = \frac{qE}{\sin \alpha} \Rightarrow \frac{mg}{\cos \frac{\alpha}{2}} = \frac{qE}{2 \sin \frac{\alpha}{2} \cos \frac{\alpha}{2}}$$

$$\Rightarrow qE = mg \, 2 \sin\left(\frac{\alpha}{2}\right)$$

$$\Rightarrow \frac{q2kp}{\left[2\ell \sin \frac{\alpha}{2}\right]^3} = mg \, 2 \sin\left(\frac{\alpha}{2}\right) \Rightarrow \frac{kpq}{\left[2\ell \sin \frac{\alpha}{2}\right]^2} = mg \sin\left(\frac{\alpha}{2}\right) \times \left(2\ell \sin \frac{\alpha}{2}\right)$$

$$\Rightarrow \frac{kpq}{\left[2\ell \sin \frac{\alpha}{2}\right]^2} = mgh \Rightarrow \text{substituting this in equation (i)}$$

$$U_f = mgh + \frac{kpq}{\left[2\ell \sin \frac{\alpha}{2}\right]^2}$$

$$\Rightarrow U_f = 2mgh$$

$$W = \Delta U = Nmgh = N = 2$$

6. A thermally isolated cylindrical closed vessel of height 8 m is kept vertically. It is divided into two equal parts by a diathermic (perfect thermal conductor) frictionless partition of mass 8.3 kg. Thus the partition is held initially at a distance of 4 m from the top, as shown in the schematic figure below. Each of the two parts of the vessel contains 0.1 mole of an ideal gas at temperature 300 K. The partition is now released and moves without any gas leaking from one part of the vessel to the other. When equilibrium

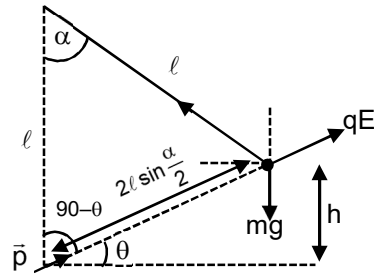

is reached, the distance of the partition from the top (in m) will be _____ (take the acceleration due to gravity = 10 ms^{-2} and the universal gas constant = $8.3 \text{ J mol}^{-1}\text{K}^{-1}$).

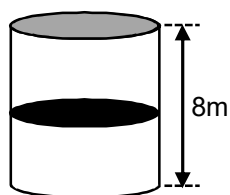

Ans. 6

Sol. Assuming temperature remains constant at 300 K

From $P_1V_1 = P_2V_2$

$$\frac{P_1 \left(\frac{V_0}{2} \right)}{T} = \frac{P'_1 \left(\frac{V_0}{2} - Ax \right)}{T}$$

$(P'_1 - P_2)A = mg$

$$\left[\frac{P_1 \left(\frac{V_0}{2} \right)}{\frac{V_0}{2} - Ax} - \frac{P_2 \left(\frac{V_0}{2} \right)}{\frac{V_0}{2} + Ax} \right] A = mg$$

$$nRT \left[\frac{1}{4-x} - \frac{1}{4+x} \right] = mg$$

$$(0.1)(8.3) \left[\frac{4+x-4+x}{16-x^2} \right] = mg$$

$$3 \left(\frac{2x}{16-x^2} \right) = 1$$

$$6x = 16 - x^2$$

$$x^2 + 6x - 16 = 0$$

$$x = 2$$

$$\text{distance} = 4 + 2 = 6\text{m}$$

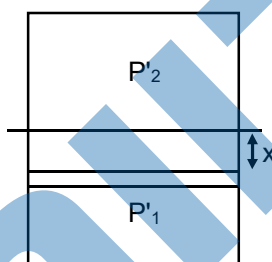

SECTION-2 : (Maximum Marks : 24)

- This section contains **SIX (06)** questions.
- Each question has **FOUR** options. **ONE OR MORE THAN ONE** of these four option(s) is(are) correct answer(s).
- For each question, choose the option(s) corresponding to (all) the correct answer(s).
- Answer to each question will be evaluated according to the following marking scheme :
- **Full Marks** : **+4** If only (all) the correct option(s) is(are) chosen;
- **Partial Marks** : **+3** If all the four options are correct but **ONLY** three options are chosen;
- **Partial Marks** : **+2** If three or more options are correct but **ONLY** two options are chosen, both of which are correct;
- **Partial Marks** : **+1** If two or more options are correct but **ONLY** one option is chosen and it is a correct option;
- **Zero Marks** : **0** If none of the options is chose (i.e. the question is unanswered);
- **Negative Marks** : **-2** In all other cases

7. A beaker of radius r is filled with water (refractive index $\frac{4}{3}$) up to a height H as shown in the figure on the left. The beaker is kept on a horizontal table rotating with angular speed ω . This makes the water surface curved so that the difference in the height of water level at the center and at the circumference of the beaker is h ($h \ll H$, $h \ll r$), as shown in the figure on the right. Take this surface to be approximately spherical with a radius of curvature R . Which of the following is/are correct? (g is the acceleration due to gravity)

(A) $R = \frac{h^2 + r^2}{2h}$

(B) $R = \frac{3r^2}{2h}$

(C) Apparent depth of the bottom of the beaker is close to $\frac{3H}{2} \left(1 + \frac{\omega^2 H}{2g} \right)^{-1}$

(D) Apparent depth of the bottom of the beaker is close to $\frac{3H}{4} \left(1 + \frac{\omega^2 H}{4g} \right)^{-1}$

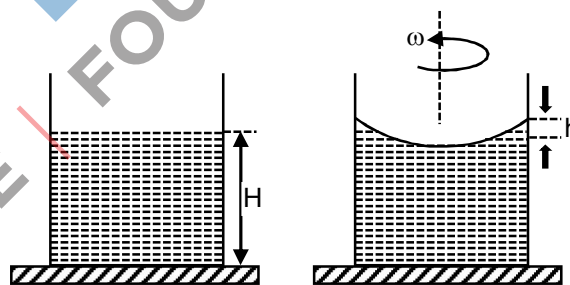

Ans. A, D

Sol. In $\triangle OAB$

$$R^2 = (R - h)^2 + r^2$$

$$R^2 = R^2 - 2hR + h^2 + r^2$$

$$\Rightarrow 2hR = h^2 + r^2$$

$$\Rightarrow R = \frac{h^2 + r^2}{2h}$$

Now considering equation of surface

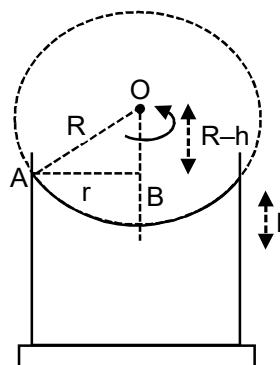

$$y = y_0 + \frac{\omega^2 r^2}{2g}$$

$$h = \frac{\omega^2 r^2}{2g}$$

Now using : $\frac{\mu_2}{v} - \frac{\mu_1}{u} = \frac{\mu_2 - \mu_1}{R}$

$$\Rightarrow \frac{1}{v} - \frac{4}{3(H-h)} = \frac{1-4/3}{-R}$$

$$\Rightarrow \frac{1}{v} = \frac{1}{3R} - \frac{4}{3H}$$

$$\Rightarrow \frac{1}{v} = \frac{2h}{3r^2} - \frac{4}{3H}$$

$$\Rightarrow \frac{1}{v} = -\frac{4}{3H} \left[1 - \frac{\omega^2 H}{4g} \right]$$

$$\Rightarrow v = \frac{3H}{4} \left[1 + \frac{\omega^2 H}{4g} \right]^{-1}$$

8. A student skates up a ramp that makes an angle 30° with the horizontal. He/she starts (as shown in the figure) at the bottom of the ramp with speed v_0 and wants to turn around over a semicircular path xyz of radius R during which he/she reaches a maximum height h (at point y) from the ground as shown in the figure. Assume that the energy loss is negligible and the force required for this turn at the highest point is provided by his/her weight only. Then (g is the acceleration due to gravity)

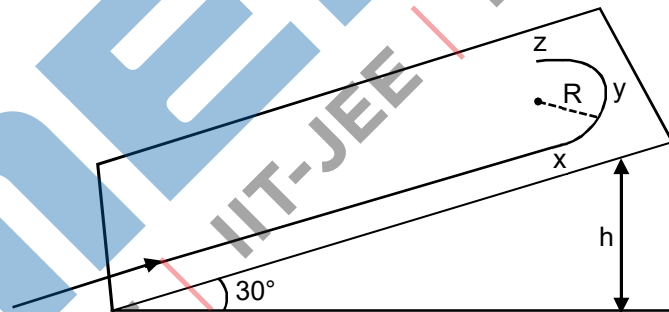

(A) $v_0^2 - 2gh = \frac{1}{2}gR$

(B) $v_0^2 - 2gh = \frac{\sqrt{3}}{2}gR$

(C) the centripetal force required at points x and z is zero

(D) the centripetal force required is maximum at points x and z

Ans. A, D

Sol. By the energy conservation (ME) between bottom point and point Y

$$\frac{1}{2}mv_0^2 = mgh + \frac{1}{2}mv_1^2$$

$$\therefore v_1^2 = v_0^2 - 2gh \dots (i)$$

Now at point Y the centripetal force provided by the component of mg

$$\therefore mg \sin 30^\circ = \frac{mv_1^2}{R}$$

$$\therefore v_1^2 = \frac{gR}{2}$$

\therefore from (i)

$$\frac{gR}{2} = v_0^2 - 2gh$$

At point x and z of circular path, the points are at same height but less than h. So the velocity more than a point y.

So required centripetal = $\frac{mv^2}{r}$ is more.

9. A rod of mass m and length L, pivoted at one of its ends, is hanging vertically. A bullet of the same mass moving at speed v strikes the rod horizontally at a distance x from its pivoted end and gets embedded in it. The combined system now rotates with angular speed ω about the pivot. The maximum angular speed ω_M is achieved for $x = x_M$. Then

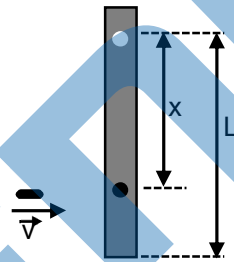

(A) $\omega = \frac{3vx}{L^2 + 3x^2}$

(B) $\omega = \frac{12vx}{L^2 + 12x^2}$

(C) $x_M = \frac{L}{\sqrt{3}}$

(D) $\omega_M = \frac{v}{2L}\sqrt{3}$

Ans. A, C, D

Sol.

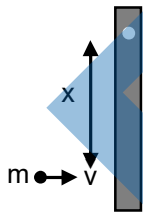

by the angular momentum conservation about the suspension point.

$$mvx = \left(\frac{m\ell^2}{3} + mx^2 \right) \omega$$

$$\therefore \omega = \frac{mvx}{\frac{m\ell^2}{3} + mx^2} = \frac{2vx}{\ell^2 + 3x}$$

For maximum $\omega \Rightarrow \frac{d\omega}{dx} = 0$

$$\therefore x_M = \frac{\ell}{\sqrt{3}}$$

So the $\omega = \frac{v}{2\ell} \sqrt{3}$

10. In an X-ray tube, electrons emitted from a filament (cathode) carrying current I hit a target (anode) at a distance d from the cathode. The target is kept at a potential V higher than the cathode resulting in emission of continuous and characteristic X-rays. If the filament current I is decreased to $\frac{I}{2}$, the potential difference V is increased to $2V$, and the separation distance d is reduced to $\frac{d}{2}$, then
- (A) the cut-off wavelength will reduce to half, and the wavelengths of the characteristic X-rays will remain the same
 - (B) the cut-off wavelength as well as the wavelengths of the characteristic X-rays will remain the same
 - (C) the cut-off wavelength will reduce to half, and the intensities of all the X-rays will decrease
 - (D) the cut-off wavelength will become two times larger, and the intensity of all the X-rays will decrease

Ans. A, C

Sol. $\lambda_{\min} = \frac{hc}{eV}$

$$\Rightarrow \lambda_{\min} \propto \frac{1}{V} \Rightarrow (\lambda_{\min})_{\text{new}} = \frac{\lambda_2}{2}$$

$$\therefore I = \frac{dN}{dt} \times \frac{hc}{\lambda}$$

$$\therefore \frac{dN}{dt} \text{ decreases}$$

Hence I decreases

11. Two identical non-conducting solid spheres of same mass and charge are suspended in air from a common point by two non-conducting, massless strings of same length. At equilibrium, the angle between the strings is α . The spheres are now immersed in a dielectric liquid of density 800 kg m^{-3} and dielectric constant 21. If the angle between the strings remains the same after the immersion, then
- (A) electric force between the spheres remains unchanged
 - (B) electric force between the spheres reduces
 - (C) mass density of the spheres is 840 kg m^{-3}
 - (D) the tension in the strings holding the spheres remains unchanged

Ans. A, C

Sol. The net electric force on any sphere is lesser but by Coulomb law the force due to one sphere to another remain the same.

In equilibrium

$$T \cos \frac{\alpha}{2} = mg$$

$$\text{and } T \sin \frac{\alpha}{2} = F$$

After immersed in dielectric liquid.

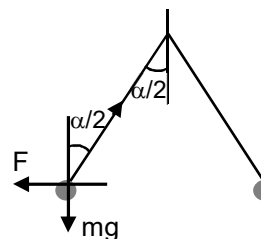

As given no change in angle α .

$$\text{So } T \cos \frac{\alpha}{2} = mg - V\rho g$$

when $\rho = 800 \text{ Kg/m}^3$

$$\text{and } T \sin \frac{\alpha}{2} = \frac{F}{e_r}$$

$$\therefore \frac{mg}{F} = \frac{mg - V\rho g}{\frac{F}{e_r}}$$

$$\frac{1}{e_r} = 1 - \frac{\rho}{d}$$

$d =$ density of sphere

$$\frac{1}{21} = 1 - \frac{800}{d}$$

$d = 840$

12. Starting at time $t = 0$ from the origin with speed 1 ms^{-1} , a particle follows a two-dimensional trajectory in the x - y plane so that its coordinates are related by the equation $y = \frac{x^2}{2}$. The x and y components of its acceleration are denoted by a_x and a_y , respectively. Then
- (A) $a_x = 1 \text{ ms}^{-2}$ implies that when the particle is at the origin, $a_y = 1 \text{ ms}^{-2}$
 - (B) $a_x = 0$ implies $a_y = 1 \text{ ms}^{-2}$ at all times
 - (C) at $t = 0$, the particle's velocity points in the x -direction
 - (D) $a_x = 0$ implies that at $t = 1 \text{ s}$, the angle between the particle's velocity and the x axis is 45°

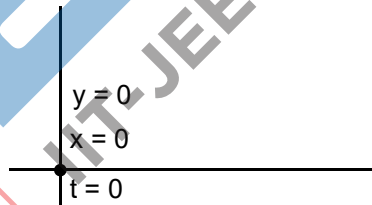

Ans. A, B, C, D

Sol. $y = \frac{x^2}{2}$

at $t = 0, \begin{cases} x = 0, y = 0 \\ u = 1 \end{cases}$ given

$$y = \frac{x^2}{2}$$

$$\frac{dy}{dt} = \frac{1}{2} \cdot 2x \frac{dx}{dt}$$

$$\Rightarrow v_y = xv_x$$

difference wrt time

$$a_y = \frac{dx}{dt} \cdot v_s + x a_x$$

$$a_y = v_s^2 + x a_x$$

Option

(A) If $a_x = 1$ and particle is at origin

$$(x = 0, y = 0)$$

$$a_y = v_x^2$$

$$a_y = 12 = 1$$

At origin, at $t = 0$ sec

speed = 1 given

(B) Option

$$a_y = v_x^2 + x a_x$$

given in option B, $a_x = 0$

$$\Rightarrow a_y = v_x^2$$

If $a_x = 0$, $v_x = \text{constant} = 1$, (all the time)

$$\Rightarrow a_y = 1^2 = 1 \text{ (all the time)}$$

(C) at $t = 0$, $x = 0$ $v_y = x v_x$

speed = 1

$$v_y = 0$$

$$v_x = 1$$

(D) $a_y = v_x^2 + x a_x$

$$v_y = x v_x$$

$a_x = 0$ (given in D option)

$$\Rightarrow a_y = v_x^2$$

If $a_x = 0 \Rightarrow v_x = \text{constant initially}$ ($v_x = 1$)

$$\Rightarrow a_y = 1^2 = 1$$

at $t = 1$ sec

$$v_y = 0 + a_y \times t = 1 \times 1 = 1$$

$$\tan \theta = \frac{v_y}{v_x} = 1$$

($\theta \rightarrow$ angle with x axis)

$$\tan \theta = \frac{v_y}{v_x} = \frac{1}{1} = 1$$

$$\theta = 45^\circ$$

SECTION-3 : (Maximum Marks : 24)

This section contains **SIX (06)** questions. The answer to each question is a **NUMERICAL VALUE**.

For each question, enter the correct numerical value of the answer using the mouse and the on-screen virtual numeric keypad in the place designated to enter the answer. If the numerical value has more than two decimal places, **truncate/round-off** the value to **TWO** decimal places.

Answer to each question will be evaluated according to the following marking scheme :

Full Marks : +4 If ONLY the correct numerical value is entered;

Zero Marks : 0 In all other cases.

- 13.** A spherical bubble inside water has radius R. Take the pressure inside the bubble and the water pressure to be p_0 . The bubble now gets compressed radially in an adiabatic manner so that its radius becomes (R - a). For $a \ll R$ the magnitude of the work done in the process is given by $(4\pi p_0 R a^2)X$, where X is a constant and $\gamma = C_p/C_v = 41/30$. The value of X is _____.

Ans. 2.05

Sol. $W = (\Delta P)_{avg} \times 4\pi R^2 a$

$$= \left| \frac{dP}{2} \cdot 4\pi R^2 a \right|$$

{for small change $(\Delta P)_{avg} < P >$ arithmetic mean}

$$= PV^\gamma = c \Rightarrow dP = -\gamma \frac{P}{V} dV = -\frac{\gamma P_0}{V} 4\pi R^2 a$$

$$= \frac{\gamma P_0}{2V} \times 4\pi R^2 a \times 4\pi R^2 a$$

$$= \frac{\gamma P_0}{2 \times 4\pi R^3} \times 4\pi R^2 a \times 4\pi R^2 a$$

$$= (4\pi R P_0 \times a^2) \frac{3\gamma}{2}$$

$\therefore x \approx 2.05$

- 14.** In the balanced condition, the values of the resistances of the four arms of a Wheatstone bridge are shown in the figure below. The resistance R_3 has temperature coefficient $0.0004 \text{ }^\circ\text{C}^{-1}$. If the temperature of R_3 is increased by $100 \text{ }^\circ\text{C}$, the voltage developed between S and T will be _____ volt.

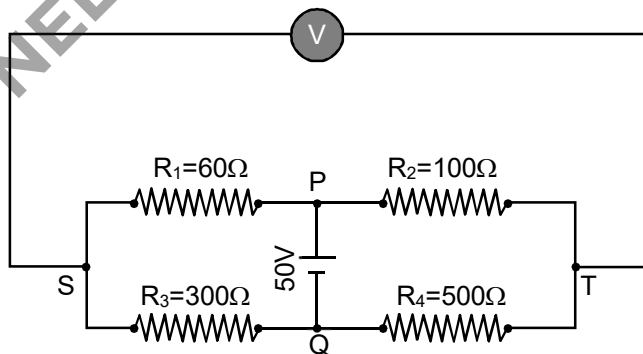

Ans. 0.26 To 0.27

Sol. $R'_3 = 300 (1 + \alpha \Delta T)$

= 312 Ω

Now

$$I_1 = \frac{50}{372} \text{ and } I_2 = \frac{50}{600}$$

$$V_S - V_T = 312 I_1 - 500 I_2$$

$$= 41.94 - 41.67$$

$$= 0.27 \text{ V}$$

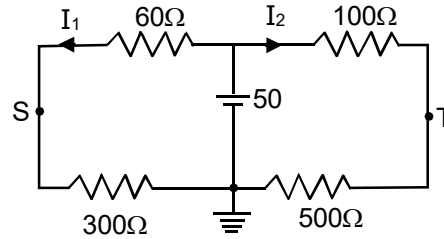

15. Two capacitors with capacitance values $C_1 = 2000 \pm 10 \text{ pF}$ and $C_2 = 3000 \pm 15 \text{ pF}$ are connected in series. The voltage applied across this combination is $V = 5.00 \pm 0.02 \text{ V}$. The percentage error in the calculation of the energy stored in this combination of capacitors is _____.

Ans. 1.30

Sol.
$$U = \frac{1}{2} \frac{C_1 C_2}{C_1 + C_2} V^2$$

$$\text{Let } C_{eq} = \frac{C_1 C_2}{C_1 + C_2}$$

$$\frac{1}{C_{eq} \pm \Delta C_{eq}} = \frac{1}{C_1 \pm \Delta C_1} + \frac{1}{C_2 \pm \Delta C_2}$$

$$\Rightarrow C_{eq} \pm \Delta C_{eq} = \frac{C_1 C_2 + C_1 \Delta C_2 + C_2 \Delta C_1}{C_1 + C_2 + \Delta C_1 + \Delta C_2}$$

$$= \frac{1200 \left(1 \pm \frac{12}{1200} \right)}{\left(1 \pm \frac{25}{5000} \right)}$$

$$= 1200 \left[1 \pm \left(\frac{1}{100} - \frac{1}{200} \right) \right]$$

$$\frac{\Delta U}{U} \times 100 = \frac{\Delta C_{eq}}{C_{eq}} \times 100 + \frac{2\Delta V}{V} \times 100$$

$$= \frac{1}{200} \times 100 + 2 \times \frac{0.02}{5} \times 100$$

$$= 1.3 \%$$

16. A cubical solid aluminium (bulk modulus = $-V \frac{dP}{dV} = 70 \text{ GPa}$) block has an edge length of 1 m on the surface of the earth. It is kept on the floor of a 5 km deep ocean. Taking the average density of water and the acceleration due to gravity to be 10^3 kg m^{-3} and 10 ms^{-2} , respectively, the change in the edge length of the block in mm is _____.

Ans. 0.23 To 0.24

Sol.
$$\frac{dV}{V} = \frac{3da}{a}$$

$$B = -V \frac{dP}{dV} = \frac{-V(\rho gh)}{dV} = \frac{-\rho gh}{3da} a$$

$$70 \times 10^9 = \frac{1 \times 5000 \times 10^3 \times 10 \times 1}{3 \times da}$$

$$da = \Delta a = \frac{5}{21} \times 10^{-2} \text{ m} = 2.38 \text{ mm}$$

17. The inductors of two LR circuits are placed next to each other, as shown in the figure. The values of the self-inductance of the inductors, resistances, mutual-inductance and applied voltages are specified in the given circuit. After both the switches are closed simultaneously, the total work done by the batteries against the induced EMF in the inductors by the time the currents reach their steady state values is _____ mJ.

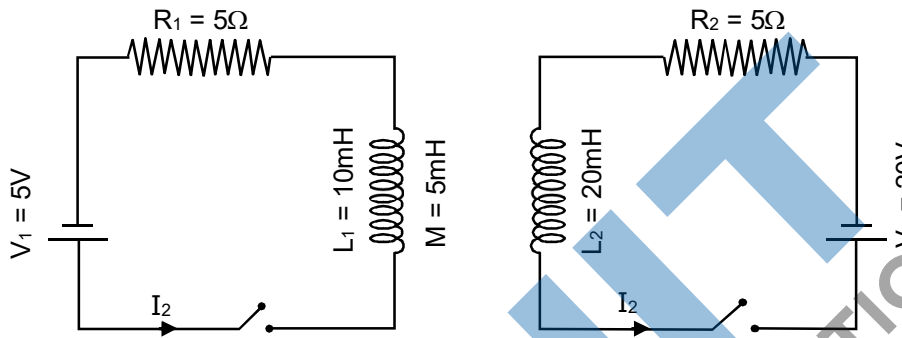

Ans. 55.00

Sol. Mutual inductance is producing flux in same direction as self inductance.

$$\therefore U = \frac{1}{2} L_1 I_1^2 + \frac{1}{2} L_2 I_2^2 + M I_1 I_2$$

$$\Rightarrow U = \frac{1}{2} \times (10 \times 10^{-3})^2 + \frac{1}{2} (20 \times 10^{-3}) \times 2^2 + (5 \times 10^{-3}) \times 1 \times 2$$

$$= 55 \text{ mJ}$$

18. A container with 1 kg of water in it is kept in sunlight, which causes the water to get warmer than the surroundings. The average energy per unit time per unit area received due to the sunlight is 700 W m^{-2} and it is absorbed by the water over an effective area of 0.05 m^2 . Assuming that the heat loss from the water to the surroundings is governed by Newton's law of cooling, the difference (in $^\circ\text{C}$) in the temperature of water and the surroundings after a long time will be _____. (Ignore effect of the container, and take constant for Newton's law of cooling = 0.001 s^{-1} , Heat capacity of water = $4200 \text{ J kg}^{-1} \text{ K}^{-1}$)

Ans. 8.33

Sol. $\frac{dQ}{dt} = \sigma e A (T^4 - T_0^4) \dots (i)$

$$\frac{dQ}{A dt} = e \sigma ((T_0 + \Delta T)^4 - T_0^4) = \sigma T_0^4 \left[\left(1 + \frac{\Delta T}{T_0} \right)^4 - 1 \right]$$

$$= e \sigma T_0^4 \left[\left(1 + 4 \frac{\Delta T}{T_0} \right) - 1 \right]$$

$$\frac{dQ}{A dt} = e\sigma T_0^3 \cdot 4\Delta T \quad \dots(ii)$$

Now from equ. (i)

$$ms \frac{dT}{dt} = \sigma e T (T^4 - T_0^4)$$

$$\frac{dT}{dt} = \frac{\sigma e A}{ms} [(T_0 + \Delta T)^4 - T_0^4]$$

$$= \frac{\sigma e A}{ms} T_0^4 \times \left[\left(1 + \frac{\Delta T}{T_0} \right)^4 - 1 \right]$$

$$\frac{dT}{dt} = \frac{\sigma e A}{ms} T_0^4 \cdot 4\Delta T$$

$$\frac{dT}{dt} = e\Delta T ; \left(K = \frac{4\sigma e A T_0^3}{ms} \right)$$

$$\Rightarrow 4\sigma e A T_0^3 = \frac{K}{A} (ms)$$

from equ. (i)

$$\frac{dQ}{A dt} = e\sigma T_0^3 \cdot 4\Delta T$$

$$700 = (K/A) (ms) \Delta T$$

$$\therefore \Delta T = \frac{700 \times 5 \times 10^{-3}}{10^{-3} \times 4200} = \frac{50}{6} = \frac{25}{3}$$

$$\Delta T = 8.33$$

PART-B : CHEMISTRY

SECTION – 1 : (Maximum Marks : 18)

- This section contains **SIX (06)** questions.
- The answer to each question is a **SINGLE DIGIT INTEGER** ranging from 0 to 9, **BOTH INCLUSIVE**
- For each question, enter the correct integer corresponding to the answer using the mouse and the on-screen virtual numeric keypad in the place designated to enter the answer.
- Answer to each question will be evaluated according to the following marking scheme :
Full Marks : +3 If ONLY the correct option is chosen;
Zero Marks : 0 If none of the options is chosen (i.e. the question is unanswered);
Negative Marks : -1 In all other cases.

19. The 1st, 2nd and the 3rd ionization enthalpies I_1 , I_2 and I_3 , of four atoms with atomic numbers n , $n+1$, $n+2$ and $n+3$, where $n < 10$, are tabulated below. What is the value of n ?

Atomic Number	Ionization Enthalpy (kJ/mol)		
	I_1	I_2	I_3
n	1681	3374	6050
$n + 1$	2081	3952	6122
$n + 2$	496	4862	6910
$n + 3$	738	1451	7733

Ans. 9
Sol.

Atomic Number	Ionization Enthalpy (kJ/mol)		
	I_1	I_2	I_3
n	1681	3374	6050
$n + 1$	2081	3952	6122
$n + 2$	496	4862	6910
$n + 3$	738	1451	7733

By observing the values of I_1 , I_2 & I_3 for atomic number $(n+2)$, it is observed that $I_2 \gg I_1$.

This indicates that number of valence shell electrons is 1 and atomic number $(n+2)$ should be an alkali metal.

Also for atomic number $(n+3)$, $I_3 \gg I_2$.

This indicates that it will be an alkaline earth metal which suggests that atomic number $(n+1)$ should be a noble gas & atomic number (n) should belong to Halogen family. Since $n < 10$; hence $n = 9$ (F atom)

Note : $n = 1$ (H atom) cannot be the answer because it does not have I_2 & I_3 values.

20. Consider the following compounds in the liquid form :
 O_2 , HF, H_2O , NH_3 , H_2O_2 , CCl_4 , $CHCl_3$, C_6H_6 , C_6H_5Cl .

When a charged comb is brought near their flowing stream, how many of them show deflection as per the following figure?

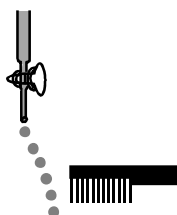

Ans. 6

Sol. Here polar molecules in the liquid form will be attracted/deflected near charged comb.

Polar molecules : HF, H₂O, NH₃, H₂O₂, CHCl₃, C₆H₅Cl (6-polar molecules)

Nonpolar molecules : O₂, CCl₄, C₆H₆

21. In the chemical reaction between stoichiometric quantities of KMnO₄ and KI in weakly basic solution, what is the number of moles of I₂ released for 4 moles of KMnO₄ consumed ?

Ans. 6

Sol. $\text{KMnO}_4 + \text{KI} \longrightarrow \text{MnO}_2 + \text{I}_2$

Eq of KMnO₄ = Eq of I₂

$$4 \times 3 = n \times 2$$

$$n = 6$$

22. An acidified solution of potassium chromate was layered with an equal volume of amyl alcohol. When it was shaken after the addition of 1 mL of 3% H₂O₂, a blue alcohol layer was obtained. The blue color is due to the formation of a chromium (VI) compound 'X'. What is the number of oxygen atoms bonded to chromium through only single bonds in a molecule of X?

Ans. 4

Sol. $\text{K}_2\text{CrO}_4 + \text{H}_2\text{O}_2 \xrightarrow[\text{(In acidic medium)}]{\text{Amyl alcohol}} \text{CrO}_5$
(X)
(Blue liquid)

Here the structure of CrO₅ is :-

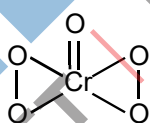

Here, single bonded O-atoms with Cr is = 04

23. The structure of a peptide is given below

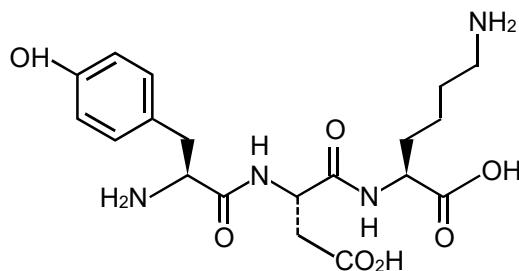

If the absolute values of the net charge of the peptide at pH = 2, pH = 6, and pH = 11 are |z₁|, |z₂| and |z₃|, respectively, then what is |z₁| + |z₂| + |z₃|?

Ans. 5

Sol. $|z_1| + |z_2| + |z_3| = 5$

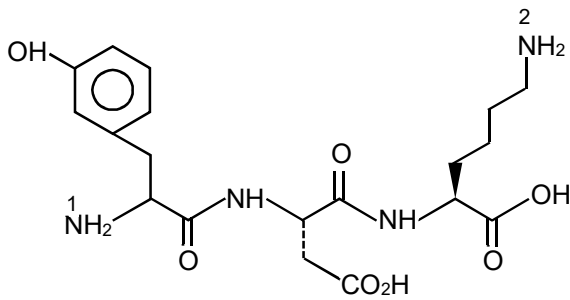

At pH = 2 NH_2^+ and NH_2^+ of Tyrosine and Lysine is +ve charged (+1 each)

$$+2 |z_1| = 2$$

At pH = 6

NH_2 of Lysine (+1),

COOH (-1) of glutamic acid,

so because of dipolar ion exist $|z_2| = 0$

At pH = 11

COOH of Glutamic acid (-1)

COOH of Lysine (-1)

OH of phenol (-1)

$$|z_3| = 3$$

24. An organic compound ($\text{C}_8\text{H}_{10}\text{O}_2$) rotates plane-polarized light. It produces pink color with neutral FeCl_3 solution. What is the total number of all the possible isomers for this compound?

Ans. 6

Sol. $\text{C}_8\text{H}_{10}\text{O}_2 \rightarrow$ Gives FeCl_3 test means Phenol derivative

↓

Rotate plane polarized light means optically active

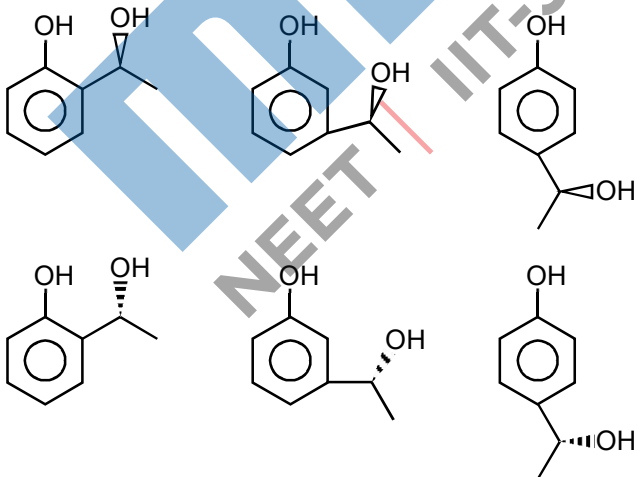

SECTION-2 : (Maximum Marks : 24)

- This section contains **SIX (06)** questions.
- Each question has **FOUR** options. **ONE OR MORE THAN ONE** of these four option(s) is(are) correct answer(s).
- For each question, choose the option(s) corresponding to (all) the correct answer(s).
- Answer to each question will be evaluated according to the following marking scheme :
- **Full Marks** : +4 If only (all) the correct option(s) is(are) chosen;
- **Partial Marks** : +3 If all the four options are correct but **ONLY** three options are chosen;
- **Partial Marks** : +2 If three or more options are correct but **ONLY** two options are chosen, both of which are correct;
- **Partial Marks** : +1 If two or more options are correct but **ONLY** one option is chosen and it is a correct option;
- **Zero Marks** : 0 If none of the options is chose (i.e. the question is unanswered);
- **Negative Marks** : -2 In all other cases

25. In an experiment, mm grams of a compound X (gas/liquid/solid) taken in a container is loaded in a balance as shown in figure I below. In the presence of a magnetic field, the pan with X is either deflected upwards (figure II), or deflected downwards (figure III), depending on the compound X. Identify the correct statement(s)

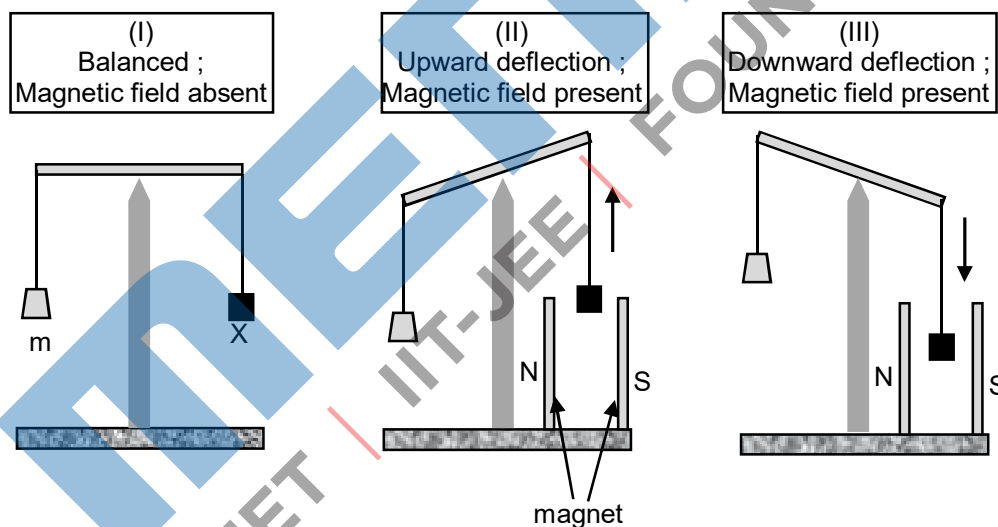

- (A) If X is $\text{H}_2\text{O}(\ell)$, deflection of the pan is upwards.
 (B) If X is $\text{K}_4[\text{Fe}(\text{CN})_6](\text{s})$, deflection of the pan is upwards.
 (C) If X is $\text{O}_2(\text{g})$, deflection of the pan is downwards.
 (D) If X is $\text{C}_6\text{H}_6(\ell)$, deflection of the pan is downwards.

Ans. A, B, C

Sol. Paramagnetic compound (X) are attracted towards magnetic field and the pan is deflected downwards. While the Diamagnetic compound (X) are repelled by magnetic field and pan is deflected upward.

- (A) $\text{X} \Rightarrow \text{H}_2\text{O} \rightarrow$ Diamagnetic (correct)
 (B) $\text{X} \Rightarrow \text{K}_4[\text{Fe}(\text{CN})_6](\text{s}) \rightarrow$ Diamagnetic (correct)

Here $Fe^{2+} + \text{Strong field ligand} \rightarrow 3d^6 \Rightarrow [t_2g^6, e_g^0]$

(C) $X \Rightarrow O_2 \rightarrow \text{Paramagnetic (correct)}$

Here $O_2(g)$ is paramagnetic due to two-unpaired electrons present in π^* (antibonding orbitals).

(D) $X \Rightarrow C_6H_6 (\ell) \rightarrow \text{Diamagnetic (Incorrect)}$

It is due to presence of 0 unpaired electrons.

26. Which of the following plots is(are) correct for the given reaction?

($[P]_0$ is the initial concentration of P)

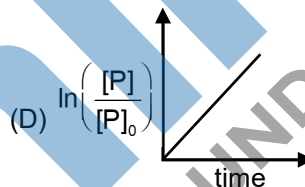
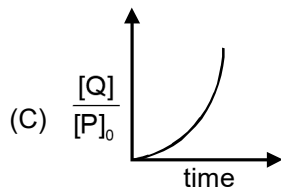
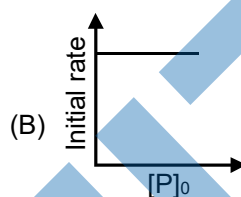
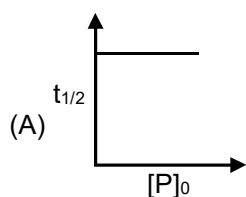
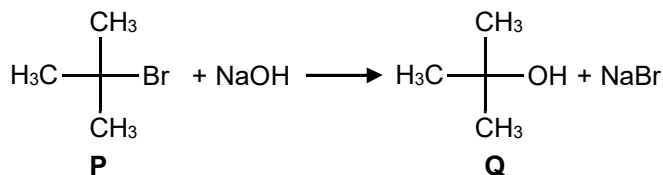

Ans. A

Sol.

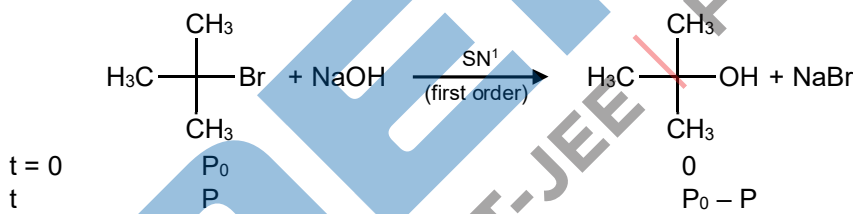

$$\text{rate} = k[\text{P}] \quad \ln \frac{P_0}{P} = kt$$

$$t_{1/2} = \frac{0.693}{K} \quad \ln \frac{P}{P_0} = -kt$$

$$\frac{[Q]}{[P]_0} = \frac{[P_0] - [P]}{[P_0]} = 1 - \frac{[P]}{[P_0]} = 1 - e^{-kt}$$

27. Which among the following statement(s) is(are) true for the extraction of aluminium from bauxite?

(A) Hydrated Al_2O_3 precipitates, when CO_2 is bubbled through a solution of sodium aluminate.

(B) Addition of Na_3AlF_6 lowers the melting point of alumina. \rightarrow

(C) CO_2 is evolved at the anode during electrolysis.

(D) The cathode is a steel vessel with a lining of carbon.

Ans. A,B,C,D

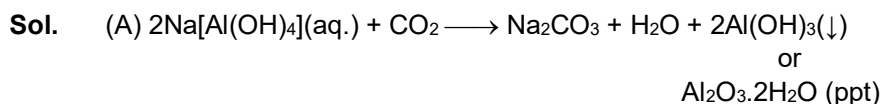

(B) Function of Na_3AlF_6 is to lower the melting point of electrolyte.

(C) During electrolysis of Al_2O_3 , the reactions at anode are :

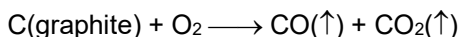
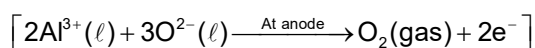

(D) The steel vessel with a lining of carbon acts as cathode.

28. Choose the correct statement(s) among the following.

(A) $\text{SnCl}_2 \cdot 2\text{H}_2\text{O}$ is a reducing agent.

(B) SnO_2 reacts with KOH to form $\text{K}_2[\text{Sn}(\text{OH})_6]$.

(C) A solution of PbCl_2 in HCl contains Pb^{2+} and Cl^- ions.

(D) The reaction of Pb_3O_4 with hot dilute nitric acid to give PbO_2 is a redox reaction.

Ans. A, B OR A, B, C

Sol. (A) $\text{SnCl}_2 \cdot 2\text{H}_2\text{O}$ is a reducing agent since Sn^{2+} tends to convert into Sn^{4+} .

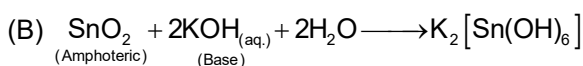

(C) First group cations (Pb^{2+}) form insoluble chloride with HCl that is PbCl_2 however it is slightly soluble in water and therefore lead +2 ion is never completely precipitated on adding hydrochloric acid in test sample of Pb^{2+} , rest of the Pb^{2+} ions are quantitatively precipitated with H_2S in acidic medium.

So that we can say that filtrate of first group contain solution of PbCl_2 in HCl which contains Pb^{2+} and Cl^-

However in the presence of conc. HCl or excess HCl it can produce $\text{H}_2[\text{PbCl}_4]$

So, we can conclude A, B or A,B,C should be answers.



It is not a redox reaction.

29. Consider the following four compounds I, II, III, and IV.

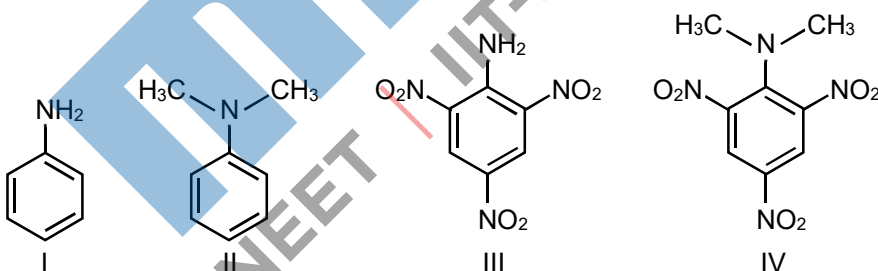

Choose the correct statement(s).

(A) The order of basicity is $\text{II} > \text{I} > \text{III} > \text{IV}$.

(B) The magnitude of pK_b difference between I and II is more than that between III and IV.

(C) Resonance effect is more in III than in IV.

(D) Steric effect makes compound IV more basic than III.

Ans. C, D

Sol.

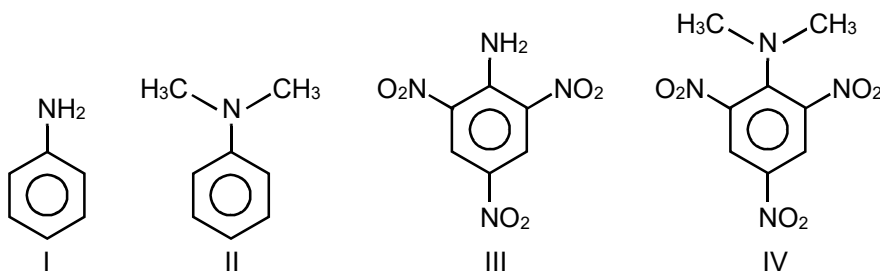

pK_b different between I and II is 0.53 and that of III and IV is 4.6.

So option (B) is incorrect

Correct Statement (C), (D)

The most basic compound in the given option is (II) and least basic compound is (III)

In 2,4,6-trinitro aniline (III) due to strong -R effect of -NO₂ groups, the l.p. of -NH₂ is more involved with benzene ring hence it has least basic strength.

Whereas (IV) N,N-Dimethyl 2,4,6-trinitro aniline, due to steric inhibition to resonance (SIR) effect; the lone pair of nitrogen is not in the plane of benzene, hence make it (l.p.) more free to protonate

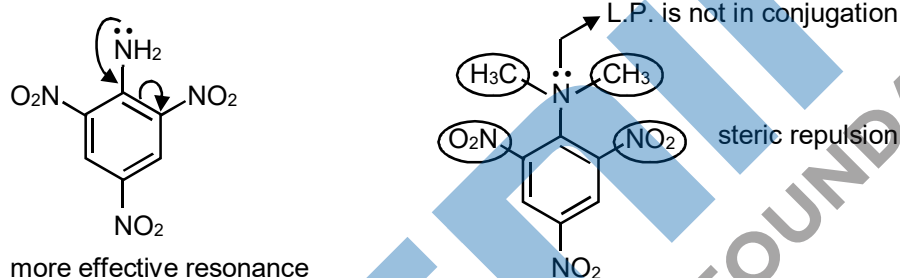

more effective resonance

30. Consider the following transformations of a compound P.

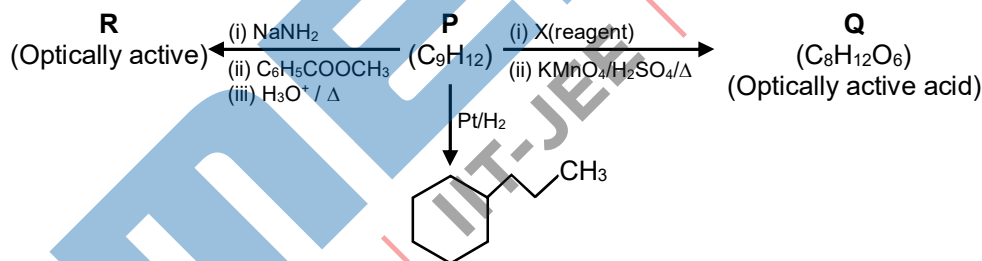

Choose the correct option(s).

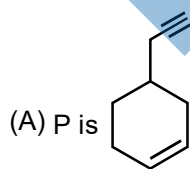

(B) X is Pd-C/quinoline/H₂

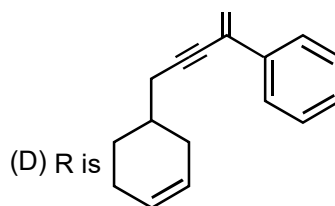
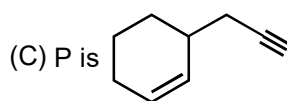

Ans. B, C

Sol.

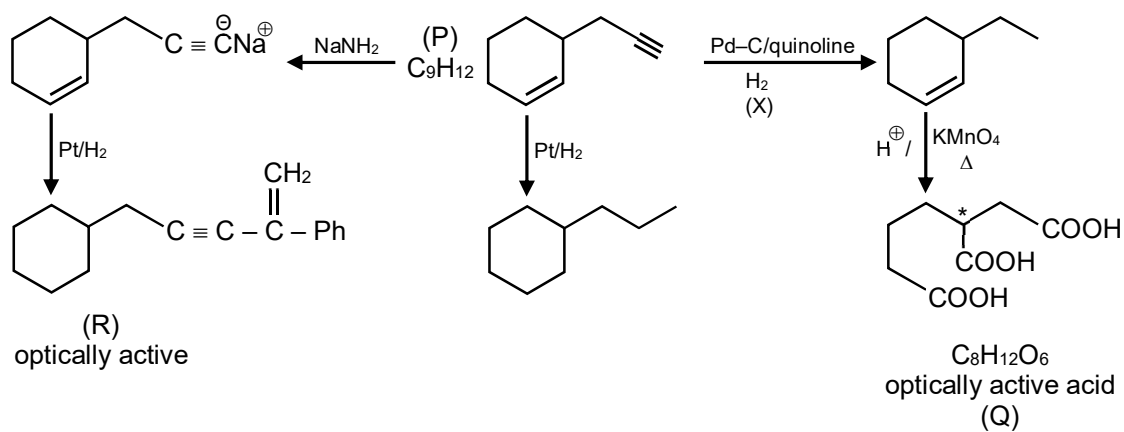

SECTION-3 : (Maximum Marks : 24)

This section contains **SIX (06)** questions. The answer to each question is a **NUMERICAL VALUE**.

For each question, enter the correct numerical value of the answer using the mouse and the on-screen virtual numeric keypad in the place designated to enter the answer. If the numerical value has more than two decimal places, **truncate/round-off** the value to **TWO** decimal places.

Answer to each question will be evaluated according to the following marking scheme :

Full Marks : +4 If ONLY the correct numerical value is entered;

Zero Marks : 0 In all other cases.

31. A solution of 0.1 M weak base (B) is titrated with 0.1 M of a strong acid (HA). The variation of pH of the solution with the volume of HA added is shown in the figure below. What is the pK_b of the base? The neutralization reaction is given by $B + HA \rightarrow BH^+ + A^-$.

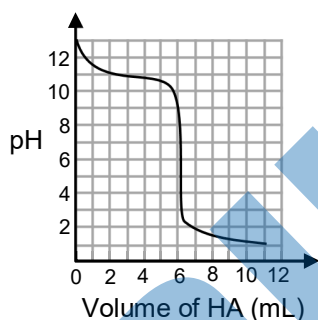

Ans. 2.30 TO 3.00

Sol. $B + HA \rightarrow BH^+ + A^-$

0.1 M, V mL

0.1 V m mol 0.1V m mol 0.1 V 0.1 V

$$[BH^+] = \frac{0.1V}{2V} = 0.05 M$$

pH at eq Pt = 500 to 0.2

$$pH = 7 - \frac{1}{2}[pK_b + \log 0.05]$$

So $pK_b = 2.30 - 2.80$

Possible

Solution-2

at V = 6 mL rxn is complete

So V = 3 mL is half of eq Pt

at which pH = 11

$$pOH = (14 - 11) = pK_b + \log 1$$

$$pK_b = 3$$

32. Liquids A and B form ideal solution for all compositions of A and B at 25°C. Two such solutions with 0.25 and 0.50 mole fractions of A have the total vapor pressures of 0.3 and 0.4 bar, respectively. What is the vapor pressure of pure liquid B in bar?

Ans. 0.20

Sol. $P_T = P_A^\circ X_A + P_B^\circ X_B$

$$0.3 = P_A^\circ \times 0.25 + P_B^\circ \times 0.75 \quad \dots(i)$$

$$0.4 = P_A^\circ \times 0.5 + P_B^\circ \times 0.5$$

$$0.8 = P_A^\circ + P_B^\circ \quad \dots(ii)$$

on solving eqⁿ (i) & (ii)

$$P_A^\circ = 0.6, \quad P_B^\circ = 0.2$$

33. The figure below is the plot of potential energy versus internuclear distance (d) of H_2 molecule in the electronic ground state. What is the value of the net potential energy E_0 (as indicated in the figure) in kJ mol^{-1} , for $d = d_0$ at which the electron-electron repulsion and the nucleus-nucleus repulsion energies are absent? As reference, the potential energy of H atom is taken as zero when its electron and the nucleus are infinitely far apart.

Use Avogadro constant as $6.023 \times 10^{23} \text{ mol}^{-1}$.

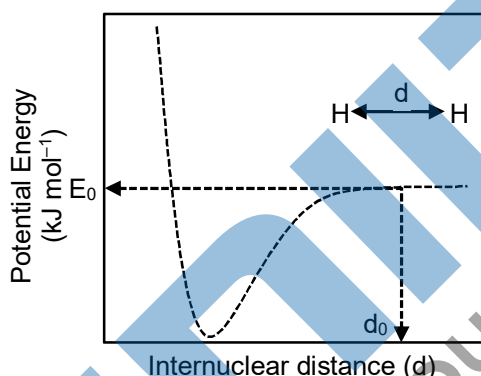

Ans. -5246.49

Sol. At $d = d_0$, nucleus-nucleus & electron-electron repulsion is absent.

Hence potential energy will be calculated for 2 H atoms. (P.E. due to attraction of proton & electron)

$$P.E. = \frac{-Kq_1q_2}{r} = \frac{(9 \times 10^9)(1.6 \times 10^{-19})}{0.529 \times 10^{-10}} = -4.355 \times 10^{-21} \text{ kJ}$$

$$\text{For 1 mol} = -4.355 \times 10^{-21} \times 6.023 \times 10^{23} = -2623.249 \text{ kJ/mol}$$

$$\text{For 2 H atoms} = -5246.49 \text{ kJ/mol}$$

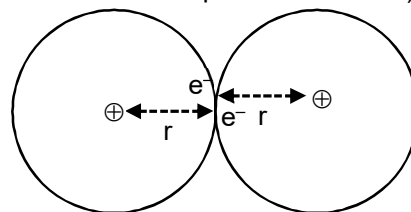

34. Consider the reaction sequence from P to Q shown below. The overall yield of the major product Q from P is 75%. What is the amount in grams of Q obtained from 9.3 mL of P? (Use density of P = 1.00 gmL^{-1} , Molar mass of C = 12.0, H = 1.0, O = 16.0 and N = 14.0 g mol^{-1})

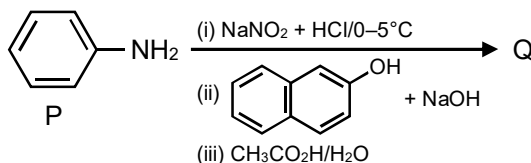

Ans. 18.60

Sol.

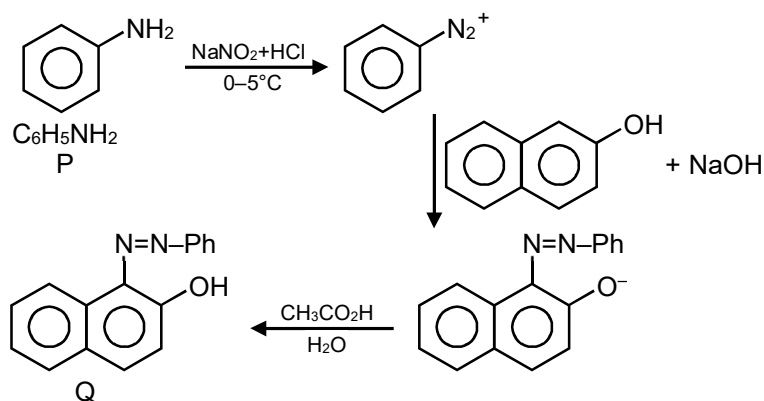

Molecular weight of

aniline = M.wt. of $\text{C}_6\text{H}_7\text{N}$

$$= 72 + 7 + 14 = 93$$

density of P = 1 g mL^{-1}

9.3 mL of P = 9.3 g P

$$= \frac{9.3}{93} = 0.1 \text{ mol P}$$

The mole ratio $\text{PhNH}_2 : \text{PhN}_2^+ :$

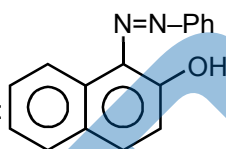

$$= 1 : 1 : 1$$

so the mole of Q formed will be 0.1 mole and extent of reaction is 100% but if it is 75% yield.

$$\text{Then amount of Q} = 0.1 \times \frac{75}{100} = 0.075 \text{ mol}$$

The molecular formula of Q = $\text{C}_{16}\text{H}_{12}\text{ON}_2$

$$\begin{aligned} \text{so M.wt. of Q} &= 16 \times 12 + 12 \times 1 + 16 + 2 \times 14 \\ &= 192 + 12 + 16 + 28 \\ &= 248 \text{ g} \end{aligned}$$

$$\begin{aligned} \text{so amount of Q} &= 248 \times 0.075 \\ &= 18.6 \text{ g} \end{aligned}$$

35. Tin is obtained from cassiterite by reduction with coke. Use the data given below to determine the minimum temperature (in K) at which the reduction of cassiterite by coke would take place.

At 298 K : $\Delta_f H^\circ(\text{SnO}_2(\text{s})) = -581.0 \text{ kJ mol}^{-1}$, $\Delta_f H^\circ(\text{CO}_2(\text{g})) = -394.0 \text{ kJ mol}^{-1}$

$$S^\circ(\text{SnO}_2(\text{s})) = 56.0 \text{ J K}^{-1} \text{ mol}^{-1}, S^\circ(\text{Sn}(\text{s})) = 52.0 \text{ J K}^{-1} \text{ mol}^{-1},$$

$$S^\circ(\text{C}(\text{s})) = 6.0 \text{ J K}^{-1} \text{ mol}^{-1}, S^\circ(\text{CO}_2(\text{g})) = 210.0 \text{ J K}^{-1} \text{ mol}^{-1}.$$

Assume that the enthalpies and the entropies are temperature independent.

Ans. 935.00

Sol. $\text{SnO}_2(\text{S}) + \text{C}(\text{S}) \longrightarrow \text{Sn}(\text{S}) + \text{CO}_2(\text{g})$

$$\Delta H^\circ_{\text{rxn}} = [-394] - [-581] = 187 \text{ kJ/mol}$$

$$\Delta S^\circ_{\text{rxn}} = [52 + 210] - [56 + 6]$$

$$= 200 \text{ J/k-mol}$$

$$T = \frac{\Delta H^\circ}{\Delta S^\circ} = \frac{187 \times 1000}{200} = 935 \text{ K}$$

36. An acidified solution of 0.05 M Zn^{2+} is saturated with 0.1 M H_2S . What is the minimum molar concentration (M) of H^+ required to prevent the precipitation of ZnS ?

Use $K_{\text{sp}}(\text{ZnS}) = 1.25 \times 10^{-22}$ and

Overall dissociation constant of H_2S , $K_{\text{NET}} = K_1K_2 = 1 \times 10^{-21}$

Ans. 0.20

Sol. For ppt, $[\text{Zn}^{2+}][\text{S}^{2-}] = K_{\text{sp}}$

$$[\text{S}^{2-}] = \frac{1.25 \times 10^{-22}}{0.05}$$

$$= 2.5 \times 10^{-21} \text{ M}$$

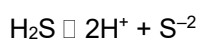

$$K_{\text{Net}} = 10^{-21} = \frac{[\text{H}^+] \times 2.5 \times 10^{-21}}{0.1}$$

$$[\text{H}^+]^2 = \frac{1}{25}$$

$$[\text{H}^+] = \frac{1}{5} \text{ M} = 0.2 \text{ M}$$

MENIIT

NEET — IIT-JEE — FOUNDATION

PART-C : MATHEMATICS

SECTION – 1 : (Maximum Marks : 18)

- This section contains **SIX (06)** questions.
- The answer to each question is a **SINGLE DIGIT INTEGER** ranging from 0 to 9, **BOTH INCLUSIVE**
- For each question, enter the correct integer corresponding to the answer using the mouse and the on-screen virtual numeric keypad in the place designated to enter the answer.
- Answer to each question will be evaluated according to the following marking scheme :
 - Full Marks** : +3 If ONLY the correct option is chosen;
 - Zero Marks** : 0 If none of the options is chosen (i.e. the question is unanswered);
 - Negative Marks** : -1 In all other cases.

36. For a complex number z , let $\text{Re}(z)$ denote the real part of z . Let S be the set of all complex numbers z satisfying $z^4 - |z|^4 = 4iz^2$, where $i = \sqrt{-1}$. Then the minimum possible value of $|z_1 - z_2|^2$, where $z_1, z_2 \in S$ with $\text{Re}(z_1) > 0$ and $\text{Re}(z_2) < 0$, is _____

Ans. 8

Sol. $z^4 - |z|^4 = 4iz^2 \Rightarrow z^4 - \bar{z}^2 = 4iz^2$
 $\Rightarrow z^2(z^2 - \bar{z}^2) = 4iz^2 \Rightarrow z^2 - \bar{z}^2 = 4i$
 $\Rightarrow (z + \bar{z})(z - \bar{z}) = 4i$
 $\Rightarrow \left(\frac{z + \bar{z}}{2}\right)\left(\frac{z - \bar{z}}{2i}\right) = 1 \Rightarrow xy = 1$

for z_1 & $z_2 \Rightarrow x_1y_1 = 1$ and $x_2y_2 = 1$

x_1 & x_2 are of opposite sign similarly

y_1 & y_2 are of opposite sign

$\Rightarrow x_1 > 0, y_1 > 0, x_2 < 0, y_2 < 0$

Now $|z_1 - z_2|^2 = (x_1 - x_2)^2 + (y_1 - y_2)^2$
 $= x_1^2 + x_2^2 + y_1^2 + y_2^2 - 2x_1x_2 - 2y_1y_2$
 $= x_1^2 + x_2^2 + y_1^2 + y_2^2 + 2x_1(-x_2) + 2y_1(-y_2)$
 $\geq 8(x_1^2 \cdot x_2^2 \cdot y_1^2 \cdot y_2^2 \cdot 2x_1(-x_2) \cdot 2y_1(-y_2))^{1/8}$
 $\geq 8((x_1y_1)^3 (x_2y_2)^3)^{1/8}$
 ≥ 8

38. The probability that a missile hits a target successfully is 0.75. In order to destroy the target completely, at least three successful hits are required. Then the minimum number of missiles that have to be fired so that the probability of completely destroying the target is NOT less than 0.95, is _____

Ans. 6

Sol. P (of destroying the target ≥ 0.95)

$${}^n C_3 \cdot \binom{3}{4}^2 \cdot \binom{1}{4}^{n-3} + {}^n C_4 \binom{3}{4}^4 \binom{1}{4}^{n-4} + \dots + {}^n C_r \binom{3}{4}^n \geq 0.95$$

$$1 - \left\{ {}^n C_0 \binom{3}{4}^0 \binom{1}{4}^n + {}^n C_1 \binom{3}{4}^1 \binom{1}{4}^{n-1} + {}^n C_2 \binom{3}{4}^2 \binom{1}{4}^{n-2} \right\} \geq 0.95$$

$$1 - \frac{95}{100} \geq \frac{1}{4^n} + \frac{3n}{4^n} + \frac{n(n-1)}{2} \cdot \frac{9}{4^n}$$

$$\frac{4^n}{20} \geq \frac{2 + 6n + 9n^2 - 9n}{2}$$

$$\frac{2^{2n-1}}{5} \geq 9n^2 - 3n + 2$$

$$2^{2n-1} \geq 5(9n^2 - 3n + 2)$$

$$n = 3 \Rightarrow 32 \geq 5 \times 74$$

$$n = 4 \Rightarrow 128 \geq 5 \times 132$$

$$n = 5 \Rightarrow 512 \geq 5 \times 212$$

$$n = 5 \Rightarrow 2048 \geq 5 \times 308$$

39. Let O be the centre of the circle $x^2 + y^2 = r^2$, where $r > \frac{\sqrt{5}}{2}$. Suppose PQ is a chord of this circle and the equation of the line passing through P and Q is $2x + 4y = 5$. If the centre of the circumcircle of the triangle OPQ lies on the line $x + 2y = 4$, then the value of r is _____

Ans. 2

Sol. M-I

$$QA = \frac{\sqrt{5}}{2}$$

$$OC = \frac{4}{\sqrt{5}}$$

$$CQ = OC = \frac{4}{\sqrt{5}} \text{ and } CA = \frac{3}{2\sqrt{5}}$$

$$\therefore OQ = \sqrt{OA^2 + AQ^2} = \sqrt{OA^2 + (CQ^2 - CA^2)}$$

$$\Rightarrow \sqrt{\frac{5}{4} + \frac{16}{5} - \frac{9}{20}} = \sqrt{4}$$

$$\Rightarrow 2 = r$$

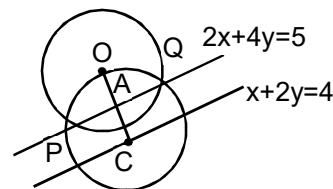

M-II

$$PQ : hx + ky = r^2$$

$$\text{Given } PQ \ 2x + 4y = 5$$

$$\Rightarrow \frac{h}{2} = \frac{k}{4} = \frac{r^2}{5} \Rightarrow h = \frac{2r^2}{5}, \ k = \frac{4r^2}{5}$$

$$\therefore C = \left(\frac{r^2}{5}, \frac{2r^2}{5} \right)$$

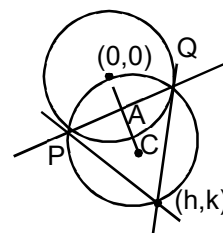

$$\therefore \quad C \text{ lies on } x + 2y = 4 \quad \Rightarrow \quad \frac{r^2}{5} + 2\left(\frac{2r^2}{5}\right) = 4$$

$$\Rightarrow \quad r^2 = 4 \Rightarrow r = 2$$

40. The trace of a square matrix is defined to be the sum of its diagonal entries. If A is a 2×2 matrix such that the trace of A is 3 and the trace of A^3 is -18 , then the value of the determinant of A is _____

Ans. 5

Sol. M-I

$$\text{Let } A = \begin{bmatrix} a & b \\ c & d \end{bmatrix} \quad A^2 = \begin{bmatrix} a^2 + bc & ab + bd \\ ac + dc & bc + d^2 \end{bmatrix}$$

$$A^3 = \begin{bmatrix} a^3 + 2abc + bdc & a^2b + abd + b^2c + bd^2 \\ a^2c + adc + bc^2 + d^2c & abc + 2bcd + d^3 \end{bmatrix}$$

$$\text{Given trace}(A) = a + d = 3$$

$$\text{and trace}(A^3) = a^3 + d^3 + 3abc + 3bcd = -18$$

$$\Rightarrow \quad a^3 + d^3 + 3bc(a + d) = -18$$

$$\Rightarrow \quad a^3 + d^3 + 9bc = -18$$

$$\Rightarrow \quad (a + d)((a + d)^2 - 3ad) + 9bc = -18$$

$$\Rightarrow \quad 3(9 - 3ad) + 9bc = -18$$

$$\Rightarrow \quad ad - bc = 5 = \text{determinant of } A$$

M - II

$$A = \begin{bmatrix} a & b \\ c & d \end{bmatrix}; \quad \Delta = ad - bc$$

$$|A - \lambda I| = (a - \lambda)(d - \lambda) - bc$$

$$= \lambda^2 - (a + d)\lambda + ad - bc$$

$$= \lambda^2 - 3\lambda + \Delta$$

$$\Rightarrow \quad 0 = A^2 - 3A + \Delta I$$

$$\Rightarrow \quad A^2 = 3A - \Delta I$$

$$\Rightarrow \quad A^3 - 3A^2 - \Delta A$$

$$= 3(3A - \Delta I) - \Delta A$$

$$= (9 - \Delta)A - 3\Delta I$$

$$= (9 - \Delta) \begin{bmatrix} a & b \\ c & d \end{bmatrix} - 3\Delta \begin{bmatrix} 1 & 0 \\ 0 & 1 \end{bmatrix}$$

$$\therefore \quad \text{trace } A^3 = (9 - \Delta)(a + d) - 6\Delta$$

$$\Rightarrow \quad -18 = (9 - \Delta)(3) - 6\Delta$$

$$= 27 - 9\Delta$$

$$\Rightarrow \quad 9\Delta = 45 \Rightarrow \Delta = 5$$

41. Let the functions : $(-1,1) \rightarrow \mathbb{R}$ and $g : (-1,1) \rightarrow (-1,1)$ be defined by

$$f(x) = |2x-1| + |2x+1| \text{ and } g(x) = x - [x],$$

where $[x]$ denotes the greatest integer less than or equal to x . Let $f \circ (-1, 1) \rightarrow \mathbb{R}$ be the composite function defined by $(f \circ g)(x) = f(g(x))$. Suppose c is the number of points in the interval $(-1, 1)$ at which $f \circ g$ is NOT continuous, and suppose d is the number of points in the interval $(-1, 1)$ at which $f \circ g$ is NOT differentiable. Then the value of $c + d$ is _____

Ans. 4

Sol. $f(x) = |2x - 1| + |2x + 1|$

$g(x) = \{x\}$

$f(g(x)) = |2\{x\} - 1| + |2\{x\} + 1|$

$$= \begin{cases} 2 & \{x\} \leq \frac{1}{2} \\ 4\{x\} & \{x\} > \frac{1}{2} \end{cases}$$

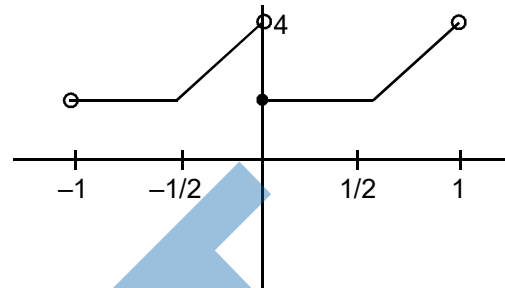

Discontinuous at $x = 0 \Rightarrow c = 1$

Non differential at $x = -\frac{1}{2}, 0, \frac{1}{2} \Rightarrow d = 3$

$\therefore c + d = 4$

42. The value of the limit

$$\lim_{x \rightarrow \frac{\pi}{2}} \frac{4\sqrt{2}(\sin 3x + \sin x)}{2 \sin 2x \sin \frac{3x}{2} + \cos \frac{5x}{2} - \left(\sqrt{2} + \sqrt{2} \cos 2x + \cos \frac{3x}{2} \right)}$$

is _____

Ans. 8

Sol. $\lim_{x \rightarrow \frac{\pi}{2}} \frac{4\sqrt{2} \cdot 2 \sin 2x \cos x}{2 \sin 2x \sin \frac{3x}{2} + \left(\cos \frac{5x}{2} - \cos \frac{3x}{2} \right) - \sqrt{2}(1 + \cos 2x)}$

$$\lim_{x \rightarrow \frac{\pi}{2}} \frac{16\sqrt{2} \sin x \cos^2 x}{2 \sin 2x \left(\sin \frac{3x}{2} - \sin \frac{x}{2} \right) - 2\sqrt{2} \cos^2 x}$$

$$\lim_{x \rightarrow \frac{\pi}{2}} \frac{16\sqrt{2} \sin x \cos^2 x}{4 \sin x \cos x \left(2 \cos x \cdot \sin \frac{x}{2} \right) - 2\sqrt{2} \cos^2 x}$$

$$\lim_{x \rightarrow \frac{\pi}{2}} \frac{16\sqrt{2} \sin x}{8 \sin x \cdot \sin \frac{x}{2} - 2\sqrt{2}} = 8$$

SECTION 2 (Maximum Marks : 24)

- This section contains **SIX (06)** questions.
- Each question has **FOUR** options. **ONE OR MORE THAN ONE** of these four option(s) is (are) correct answer(s).
- For each question, choose the option(s) corresponding to (all) the correct answer(s).
- Answer to each question will be evaluated according to the following marking scheme :

Full Marks : +4 If only (all) the correct option(s) is(are) chosen;

Partial Marks : +3 If all the four options are correct but **ONLY** three options are chosen;

Partial Marks : +2 If three or more options are correct but **ONLY** two options are chosen, both of which are correct;

Partial Marks : +1 If two or more options are correct but **ONLY** one option is chosen and it is a correct option;

Zero Marks : 0 If none of the options is chosen (i.e. the question is unanswered);

Negative Marks : -2 In all other cases.

43. Let b be a nonzero real number. Suppose $f: \mathbb{R} \rightarrow \mathbb{R}$ is a differentiable function such that $f(0)=1$. If the

derivative f' of f satisfies the equation $f'(x) = \frac{f(x)}{b^2 + x^2}$

for all $x \in \mathbb{R}$, then which of the following statements is/are TRUE?

- (A) If $b > 0$, then f is an increasing function
- (B) If $b < 0$, then f is a decreasing function
- (C) $f(x) f(-x) = 1$ for all $x \in \mathbb{R}$
- (D) $f(x) - f(-x) = 0$ for all $x \in \mathbb{R}$

Ans. A,C

Sol. $f'(x) = \frac{f(x)}{b^2 + x^2}$

$$\int \frac{f'(x)}{f(x)} dx = \int \frac{dx}{x^2 + b^2}$$

$$\Rightarrow \ln |f(x)| = \frac{1}{b} \tan^{-1}\left(\frac{x}{b}\right) + c$$

Now $f(0) = 1$

$$\therefore c = 0$$

$$\therefore |f(x)| = e^{\frac{1}{b} \tan^{-1}\left(\frac{x}{b}\right)}$$

$$\Rightarrow f(x) = \pm e^{\frac{1}{b} \tan^{-1}\left(\frac{x}{b}\right)}$$

$$\text{Since } f(0) = 1 \quad \therefore f(x) = e^{\frac{1}{b} \tan^{-1}\left(\frac{x}{b}\right)}$$

$x \rightarrow -x$

$$f(-x) = e^{-\frac{1}{b} \tan^{-1}\left(\frac{x}{b}\right)}$$

$\therefore f(x) \cdot f(-x) = e^0 = 1$ (option C)

And for $b > 0$

$f(x) = e^{\frac{1}{b} \tan^{-1}\left(\frac{x}{b}\right)}$

$\Rightarrow f(x)$ is increasing for all $x \in \mathbb{R}$ (option A)

44. Let a and b be positive real numbers such that $a > 1$ and $b < a$. Let P be a point in the first quadrant that lies on the hyperbola $\frac{x^2}{a^2} - \frac{y^2}{b^2} = 1$. Suppose the tangent to the hyperbola at P passes through the point $(1,0)$, and suppose the normal to the hyperbola at P cuts off equal intercepts on the coordinate axes. Let Δ denote the area of the triangle formed by the tangent at P , the normal at P and the x -axis. If e denotes the eccentricity of the hyperbola, then which of the following statements is/are TRUE?

- (A) $1 < e < 2$ (B) $2 < e < 2$ (C) $\Delta = a^4$ (D) $\Delta = b^4$

Ans. A, D

Sol. Since Normal at point P makes equal intercept on co-ordinate axes, therefore slope of Normal = -1

Hence slope of tangent = 1

Equation of tangent

$y - 0 = 1(x - 1)$

$y = x - 1$

Equation of tangent at (x_1, y_1)

$\frac{xx_1}{a^2} - \frac{yy_1}{b^2} = 1$

$x - y = 1$ (equation of Tangent)

on comparing $x_1 = a^2, y_1 = b^2$

Also $a^2 - b^2 = 1$... (1)

Now equation of normal at $(x_1, y_1) = (a^2, b^2)$

$y - b^2 = -1(x - a^2)$

$x + y = a^2 + b^2$ (Normal)

point of intersection with x -axis is $(a^2 + b^2)$

Now $e = \sqrt{1 + \frac{b^2}{a^2}}$

$e = \sqrt{1 + \frac{b^2}{b^2 + 1}}$ [from (1) $\frac{b^2}{b^2 + 1} < 1$]

$1 < e < \sqrt{2}$ Option (A)

$\Delta = \frac{1}{2} \cdot AB \cdot PQ$

and $\Delta = \frac{1}{2}(a^2 + b^2 - 1) \cdot b^2$

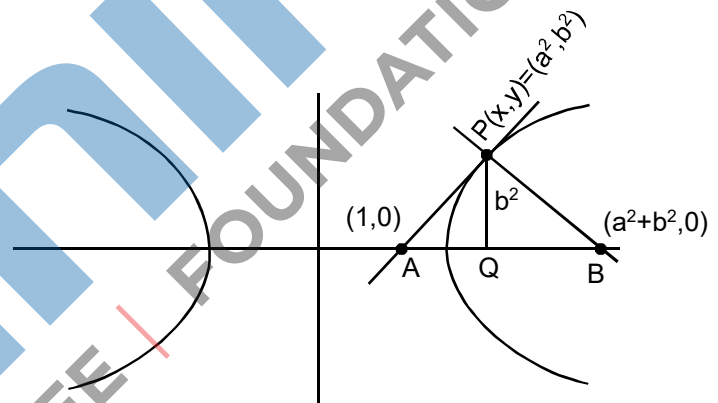

$$\Delta = \frac{1}{2}(2b^2)b^2 \text{ (from (1) } a^2 - 1 = b^2)$$

$$\Delta = b^2 \text{ so option (D)}$$

45. Let $f: \mathbb{R} \rightarrow \mathbb{R}$ and $g: \mathbb{R} \rightarrow \mathbb{R}$ be functions satisfying $f(x+y) = f(x) + f(y) + f(x)f(y)$ and $f(x) = xg(x)$ for all $x, y \in \mathbb{R}$. If $\lim_{x \rightarrow \infty} g(x) = 1$, then which of the following statements is/are TRUE?

- (A) f is differentiable at every $x \in \mathbb{R}$
- (B) If $g(0) = 1$, then g is differentiable at every $x \in \mathbb{R}$
- (C) The derivative $f'(1)$ is equal to 1
- (D) The derivative $f'(0)$ is equal to 1

Ans. A, B, D

Sol. since $f(x) = xg(x)$

$$\lim_{x \rightarrow 0} f(x) = \lim_{x \rightarrow 0} xg(x)$$

$$\lim_{x \rightarrow 0} f(x) = \left(\lim_{x \rightarrow 0} x \right) \cdot \left(\lim_{x \rightarrow 0} g(x) \right)$$

$$\lim_{x \rightarrow 0} f(x) = 0 \times 1 = 0 \quad \dots(1)$$

$$f(x + y) = f(x) + f(y) + f(x)f(y)$$

Now we check continuity of $f(x)$

at $x = a$

$$\lim_{h \rightarrow 0} f(a + h) = f(a) + f(h) + f(a)f(h)$$

$$\lim_{h \rightarrow 0} (f(a) + f(h)(1 + f(a)))$$

$$\lim_{h \rightarrow 0} f(a + h) = f(a)$$

$\therefore f(x)$ is continuous $\forall x \in \mathbb{R}$

$$\lim_{x \rightarrow 0} f(x) = f(0) = 0 \quad \left(\lim_{x \rightarrow 0} f(x) = 0 \right)$$

$$\therefore f(0) = 0$$

$$\text{and } \lim_{x \rightarrow 0} \frac{f'(x)}{1} = 1$$

$$\therefore f'(0) = 1$$

Now

$$f(x + y) = f(x) + f(y) + f(x)f(y)$$

using partial derivative (w.r.t. y)

$$f(x + y) + f'(y) + f(x) + f'(y)$$

put $y = 0$

$$f'(x) = f'(0) + f(x)f'(0)$$

$$f'(x) = 1 + f(x)$$

$$\int \frac{f'(x)}{1 + f(x)} dx = \int 1 dx$$

$$\ln|1 + f(x)| = x + C$$

$$f(0) = 0 ; c = 0 \quad \therefore |1 + f(x)| = e^x$$

$$1 + f(x) = \pm e^x \text{ or } f(x) = \pm e^x - 1$$

$$\text{Now } f(0) = 0 \quad \therefore f(x) = e^x - 1$$

$$\therefore f(x) = e^x - 1$$

$$\text{Option (A) } = e^x$$

$$\text{and } f'(x) = e^x$$

$$g(x) = \frac{f(x)}{x} = \begin{cases} \frac{e^x - 1}{x} & ; x \neq 0 \\ 1 & ; x = 0 \end{cases}$$

$$g'(0+h) \lim_{h \rightarrow 0} \frac{g(0+h) - g(0)}{h}$$

$$= \lim_{h \rightarrow 0} \frac{\frac{e^h - 1}{h} - 1}{h} = \frac{1}{2}$$

Option B is correct

46. Let $\alpha, \beta, \gamma, \delta$ be real numbers such that $\alpha^2 + \beta^2 + \gamma^2 \neq 0$ and $\alpha + \gamma = 1$. Suppose the point $(3, 2, -1)$ is the mirror image of the point $(1, 0, -1)$ with respect to the plane $\alpha x + \beta y + \gamma z = \delta$. Then which of the following statements is/are TRUE?

- (A) $\alpha + \beta = 2$ (B) $\delta - \gamma = 3$ (C) $\delta + \beta = 4$ (D) $\alpha + \beta + \gamma = \delta$

Ans. A, B, C

Sol. R is mid point of PQ

\therefore R(2, 1, -1) and it lies on plane

equation of plane is $\alpha x + \beta y + \gamma z = \delta$

$$\therefore 2\alpha + \beta - \gamma = \delta \quad \dots(1)$$

Normal vector to plane is

$$\vec{n} = 2\vec{i} + \vec{j}$$

$$\therefore \frac{\alpha}{2} = \frac{\beta}{2} = \frac{\gamma}{0} = k$$

$$\therefore \alpha = 2k, \beta = 2k, \gamma = 0 \quad \dots(2)$$

$$\text{and } \alpha + \gamma = 1 \text{ (given)} \quad \dots(3)$$

from (2) and (3)

$$\therefore \alpha = 1, \beta = 1, \gamma = 0$$

and from (1)

$$2(1) + 1 - 0 = \delta$$

$$\delta = 3$$

Now :

$$\alpha + \beta = 2$$

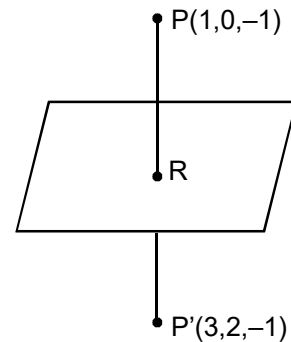

$$\delta - \gamma = 3$$

$$\delta + \beta = 4$$

so, A,B,C are correct.

47. Let a and b be positive real numbers. Suppose $\overline{PQ} = a\hat{i} + b\hat{j}$ and $\overline{PS} = a\hat{i} - b\hat{j}$ are adjacent sides of a parallelogram PQRS. Let \vec{u} and \vec{v} be the projection vectors of $\vec{w} = \hat{i} + \hat{j}$ along \overline{PQ} and \overline{PS} , respectively. If $|\vec{u}| + |\vec{v}| = |\vec{w}|$ and if the area of the parallelogram PQRS is 8, then which of the following statements is/are TRUE?
- (A) $a + b = 4$
 - (B) $a - b = 2$
 - (C) The length of the diagonal PR of the parallelogram PQRS is 4
 - (D) w is an angle bisector of the vectors PQ and PS

Ans. A, C

Sol. $\vec{u} = ((\hat{i} + \hat{j}) \cdot \overline{PQ}) / |\overline{PQ}|$

$$|\vec{u}| = |(\hat{i} + \hat{j}) \cdot \overline{PQ}| / |\overline{PQ}|$$

$$|\vec{u}| = \left| (\hat{i} + \hat{j}) \cdot \frac{(a\hat{i} + b\hat{j})}{\sqrt{a^2 + b^2}} \right| = \frac{a + b}{\sqrt{a^2 + b^2}}$$

$$\vec{v} = ((\hat{i} + \hat{j}) \cdot \overline{PS}) / |\overline{PS}|$$

$$|\vec{v}| = \left| \frac{(\hat{i} + \hat{j}) \cdot (a\hat{i} - b\hat{j})}{\sqrt{a^2 + b^2}} \right| = \frac{a - b}{\sqrt{a^2 + b^2}}$$

$$|\vec{u}| + |\vec{v}| = |\vec{w}|$$

$$\frac{|a + b| + |a - b|}{\sqrt{a^2 + b^2}} = \sqrt{2}$$

For $a > b$

$$2a = \sqrt{2} \cdot \sqrt{a^2 + b^2}$$

$$4a^2 = 2a^2 + 2b^2$$

$$a^2 + b^2 \quad \therefore \quad a = b \quad \dots(1)$$

$$(a > 0, b > 0)$$

Similarly for $a < b$ we will get $a = b$

Now area of parallelogram = $|(a\hat{i} + b\hat{j}) \times (a\hat{i} - b\hat{j})|$

$$= 2ab$$

$$\therefore \quad 2ab = 8$$

From (1) and (2)

$$a = 2, b = 2 \quad \therefore \quad a + b = 4 \quad \text{option (A)}$$

length of diagonal is

$$|2a\hat{i}| = |4\hat{i}| = 4$$

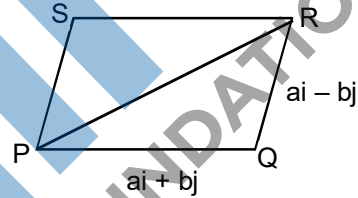

48. For non-negative integers s and r , let

$$\binom{S}{r} = \begin{cases} \frac{s!}{r!(s-r)!} & \text{if } r \leq s, \\ 0 & \text{if } r > s. \end{cases}$$

For positive integers m and n , let

$$(m,n) = \sum_{p=0}^{m+n} \frac{f(m,n,p)}{\binom{n+p}{p}}$$

where for any nonnegative integer p ,

$$f(m,n,p) = \sum_{i=0}^p \binom{m}{i} \binom{n+i}{p} \binom{p+n}{p-i}$$

Then which of the following statements is/are TRUE?

- (A) $(m,n) = g(n,m)$ for all positive integers m, n
- (B) $(m, n+1) = g(m+1, n)$ for all positive integers m, n
- (C) $(2m, 2n) = 2g(m, n)$ for all positive integers m, n
- (D) $(2m, 2n) = (g(m, n))^2$ for all positive integers m, n

Ans. A, B, D

Sol. Solving

$$f(m,n,p) = \sum_{i=0}^p {}^m C_i \cdot {}^{p+n} C_{p-i}$$

$${}^m C_i \cdot {}^{n+i} C_p \cdot {}^{p+n} C_{p-i}$$

$${}^m C_i \cdot \frac{(n+i)!}{p!(n-p+i)!} \times \frac{(n+p)!}{(p-i)!(n+i)!}$$

$${}^m C_i \times \frac{(n+p)!}{p!} \times \frac{1}{(n-p+i)!(p-i)!}$$

$${}^m C_i \times \frac{(n+p)!}{p!n!} \times \frac{n!}{(n-p+i)!(p-i)!}$$

$${}^m C_i \cdot {}^{n+p} C_p \cdot {}^n C_{p-i} \{ {}^m C_i \cdot {}^n C_{p-i} = {}^{m+n} C_p \}$$

$$f(m, n, p) = {}^{n+p} C_p \cdot {}^{m+n} C_p$$

$$\frac{f(m,n,p)}{{}^{n+p} C_p} = {}^{m+n} C_p$$

Now

$$g(m,n) = \sum_{p=0}^{m+n} \frac{f(m,n,p)}{{}^{n+p} C_p}$$

$$g(m,n) = \sum_{p=0}^{m+n} {}^{m+n} C_p$$

$$g(m, n) = 2^{m+n}$$

$$g(m,n) = q(n,m)$$

$$g(m, n+1) = 2^{m+n+1}$$

$$g(m+n, n) = 2^{m+1+n}$$

$$(D) \quad g(2m, 2n) = 2^{2m+2n} \\ = (2^{m+n})^2$$

SECTION 3 (Maximum Marks : 24)

- This section contains **SIX (06)** questions. The answer to each question is a **NUMERICAL VALUE**.
- For each question, enter the correct numerical value of the answer using the mouse and the on-screen virtual numeric keypad in the place designated to enter the answer. If the numerical value has more than two decimal places, truncate/round-off the value to **TWO** decimal places.
- Answer to each question will be evaluated according to the following marking scheme :

Full Marks : +4 If ONLY the correct numerical value is entered;

Zero Marks : 0 In all other cases.

49. An engineer is required to visit a factory for exactly four days during the first 15 days of every month and it is mandatory that no two visits take place on consecutive days. Then the number of all possible ways in which such visits to the factory can be made by the engineer during 1-15 June 2021 is _____

Ans. 495.00

Sol. Selection of 4 days out of 15 days such that no two of them are consecutive

$$= {}^{15-4+1}C_4 = {}^{12}C_4$$

$$= \frac{12 \times 11 \times 10 \times 9}{4 \times 3 \times 2} = 11 \times 5 \times 9 = 495$$

50. In a hotel, four rooms are available. Six persons are to be accommodated in these four rooms in such a way that each of these rooms contains at least one person and at most two persons. Then the number of all possible ways in which this can be done is _____

Ans. 1080.00

Sol. Required ways = $\frac{6!}{2! 2! 1! 1! 2! 2!} \times 4! = 1080$

51. Two fair dice, each with faces numbered 1,2,3,4,5 and 6, are rolled together and the sum of the numbers on the faces is observed. This process is repeated till the sum is either a prime number or a perfect square. Suppose the sum turns out to be a perfect square before it turns out to be a prime number. If p is the probability that this perfect square is an odd number, then the value of 14p is _____

Ans. 8.00

Sol. Prime : 2, 3, 5, 7, 11

1 2 4 6

$$P(\text{Prime}) = \frac{15}{36}$$

Perfect square = 4, 9

$$P(\text{perfect square}) = \frac{7}{36}$$

Required probability

$$= \frac{\frac{4}{36} + \frac{14}{36} \times \frac{4}{36} + \left(\frac{14}{36}\right)^2 \frac{4}{36} + \dots}{\frac{7}{36} + \frac{14}{36} \times \frac{7}{36} + \left(\frac{14}{36}\right)^2 \frac{7}{36} + \dots}$$

$$P = \frac{4}{7}$$

$$\therefore 14P = 14 \cdot \frac{4}{7} = 8$$

52. Let the function $f: [0, 1] \rightarrow \mathbb{R}$ be defined by $f(x) = \frac{4^x}{4^x + 2}$

Then the value of $f\left(\frac{1}{40}\right) + f\left(\frac{2}{40}\right) + f\left(\frac{3}{40}\right) + \dots + f\left(\frac{39}{40}\right) - f\left(\frac{1}{2}\right)$ is _____

Ans. 19.00

Sol. $f(x) + f(1-x) = \frac{4^x}{4^x + 2} + \frac{4^{1-x}}{4^{1-x} + 2}$

$$= \frac{4^x}{4^x + 2} + \frac{4/4^x}{4/4^x + 2}$$

$$= \frac{4^x}{4^x + 2} + \frac{4}{4 + 2 \cdot 4^x}$$

$$= \frac{4^x}{4^x + 2} + \frac{2}{2 + 4^x}$$

$$= 1$$

So, $f\left(\frac{1}{40}\right) + f\left(\frac{2}{40}\right) + \dots + f\left(\frac{39}{40}\right) - f\left(\frac{1}{2}\right)$

$$= 19 + f\left(\frac{1}{2}\right) - f\left(\frac{1}{2}\right) = 19$$

53. Let $f: \mathbb{R} \rightarrow \mathbb{R}$ be a differentiable function such that its derivative f' is continuous and $f(\pi) = -6$. If $F: [0, \pi] \rightarrow \mathbb{R}$ is defined by $F(x) = \int_0^x f(t) dt$, and if

$$\int_0^\pi (f'(x) + F(x)) \cos x dx = 2,$$

then the value of $f(0)$ is _____

Ans. 4.00

Sol. $F(x) = \int_0^x f(t) dt$

$$\Rightarrow F'(x) = f(x)$$

$$I = \int_0^\pi f'(x) \cdot \cos x dx + \int_0^\pi F(x) \cos(x) dx = 2 \quad \dots(1)$$

$$I_1 = \int_0^\pi f'(x) \cdot \cos x dx \quad (\text{Let})$$

Using by parts

$$I_1 = (\cos x \cdot f(x))_0^\pi + \int_0^\pi \sin x \cdot f(x) dx$$

$$I_1 = 6 - f(0) + \int_0^\pi \sin x \cdot F'(x) dx$$

$$I_1 = 6 - f(0) + I_2 \quad \dots(2)$$

$$I_2 = \int_0^\pi \sin x \cdot F'(x) dx$$

Using by part we get

$$I_2 = (\sin x \cdot F(x))_0^\pi - \int_0^\pi \cos x \cdot F(x) dx$$

$$I_2 = -\int_0^\pi \cos x \cdot F(x) dx$$

$$(2) \Rightarrow I_1 = 6 - f(0) - \int_0^\pi \cos x \cdot F(x) dx$$

$$(1) \Rightarrow I = 6 - f(0) = 2 \Rightarrow f(0) = 4$$

54. Let the function : $(0, \pi) \rightarrow \mathbb{R}$ be defined by

$$f(\theta) = (\sin\theta + \cos\theta)^2 + (\sin\theta - \cos\theta)^4$$

Suppose the function f has a local minimum at θ precisely when $\theta \in \{\lambda_1\pi, \dots, \lambda_r\pi\}$,

where $0 < \lambda_1 < \dots < \lambda_r < 1$. Then the value of $\lambda_1 + \dots + \lambda_r$ is _____

Ans. 0.50

Sol. $f(\theta) = (\sin\theta + \cos\theta)^2 + (\sin\theta - \cos\theta)^4$

$$f(\theta) = \sin^2 2\theta - 2\sin 2\theta + 1$$

$$\begin{aligned} f(\theta) &= \sin 2\theta \cdot (2\cos 2\theta) - 2\cos 2\theta \\ &= 2\cos 2\theta(2\sin 2\theta - 1) \end{aligned}$$

Critical points

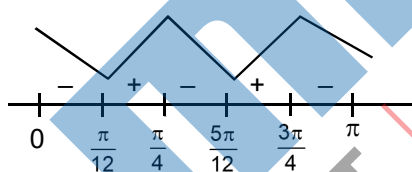

So, minimum at $\theta = \frac{\pi}{12}, \frac{5\pi}{12}$

$$\lambda_1 + \lambda_2 = \frac{1}{12} + \frac{5}{12} = \frac{6}{12} = \frac{1}{2}$$